

FS-RW3/4/5

REFRIGERATED WELL WITH LED ILLUMINATED GANTRY

Flexi-Serve mobile refrigerated unit.

Available in 4 size options to accommodate between 2 and 4 1/1 GN pans at 150mm deep.

Designed to run on one 13amp plug to minimise power consumption, whilst keeping food at the optimal serving temperature.

Use as a single servery or combine with other Flexi-Serve modules to create your perfect counter layout.

FLEXI SERVE

MADE IN BRITAIN

Model Specification	FS-RW3	FS-RW4	FS-RW5
Dimensions (w x d x h) mm	1160x700x900	1495x700x900	1830x700x900
Temperature Range (°C)	2-5	2-5	2-5
Total Power kW (Unit Only)	1.47	2.00	2.35
Total Power kW (Unit and gantry)	1.49	2.02	2.38
Number of gantry bulbs	2	2	3
Plug Type	13 Amp	13 Amp	13 Amp
Weight Packed (kg)	136	150.5	191.5
Weight Unpacked (kg)	108	128.5	169.5
Dimensions incl. Gantry & Trayslide	1160x983x1440	1495x983x1440	1830x983x1440

FEATURES

- Various colours of fascia panels available
- Narrow 700mm width fits easily through doorways
- Tubular tray slide supplied as standard
- 4 heavy duty 100mm locking castors
- 10mm deep bonded glass on gantry
- Hydrocarbon refrigeration technology offers reduced environmental impact and energy efficiency
- Automatic condensate evaporation
- Blown air refrigerated well keeps food perfectly chilled between 2 and 5 degrees
- Vents to operator side maintains overall visual impact for customers

REFRIGERATED WELL WITH LED ILLUMINATED GANTRY

FS-RW LINE DRAWING

Dimensions in mm

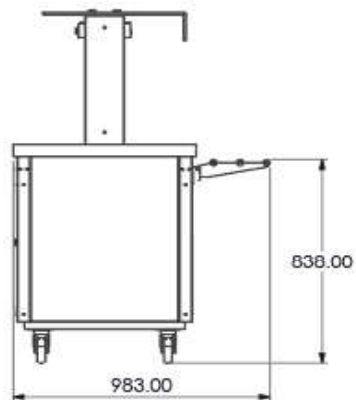
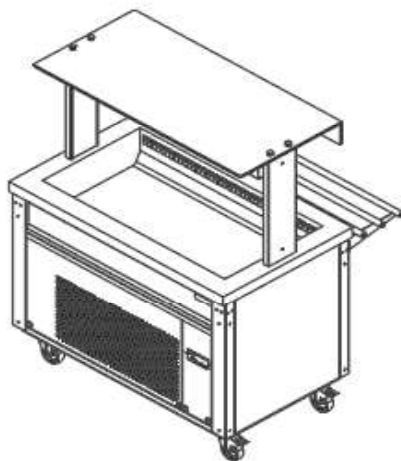
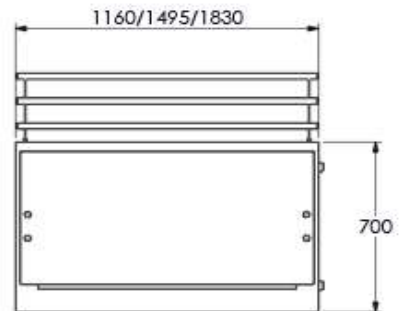

757 With tray slide in the down position

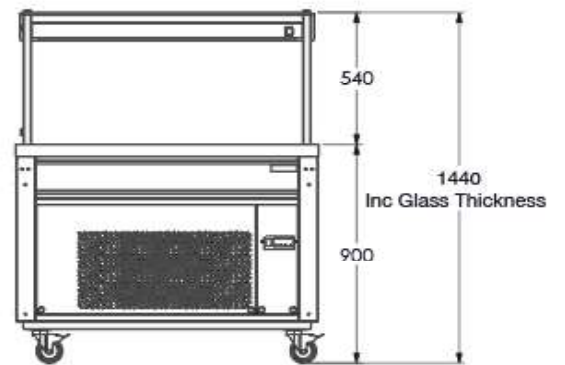

Please note air intake from the front

AVAILABLE ACCESSORIES

- Island glass or Assisted glass at an additional cost