

FS-HBW2/3/4/5

## HOT CUPBOARD WITH WET WELL BAIN MARIE AND QUARTZ HEATED GANTRY

Flexi-Serve mobile hot cupboard with wet bain marie top. Available in 4 size options to accommodate between 2 and 5 1/1 GN pans at 150mm deep. Designed to run on one plug to minimise power consumption, whilst keeping food at the optimal serving temperature. Use as a single servery or combine with other Flexi-Serve modules to create your perfect counter layout.

**FLEXI / SERVE**

Model Specification	FS-HBW2	FS-HBW3	FS-HBW4	FS-HBW5
Dimensions (w x d x h) mm	860x700x900	1160x700x900	1495x700x900	1830x700x900
Temperature Range (°C)	30-90	30-90	30-90	30-90
Total Power KW)	3.1	3.3	4.7	4.9
Plug Type	16 Amp Commando	16 Amp Commando	32 Amp Commando	32 Amp Commando
Weight Packed (kg)	96	136	150.5	191.5
Weight Unpacked (kg)	86	108	128.5	169.5
Dimensions incl. Gantry & Trayslide	860x983x1440	1160x983x1440	1495x983x1440	1830x983x1440

### FEATURES

- GN compatible wet-well Bain Marie accommodates 150mm deep pans, bridging bars supplied
- Fan assisted hot cupboard with wire shelves holds food at ideal temperature for service
- Removable hot cupboard shelves and supports makes cleaning easier, shelves fit in a dishwasher
- Various colours of fascia panels available
- Adjustable hot cupboard shelf positions offer increased flexibility and capacity when required
- Narrow 700mm width fits easily through doorways
- 4 locking castors makes it easy to move for cleaning or storage
- Tubular tray slide supplied as standard

# HOT CUPBOARD WITH WET WELL BAIN MARIE AND QUARTZ HEATED GANTRY

## FS-HBW2 LINE DRAWING

Dimensions in mm

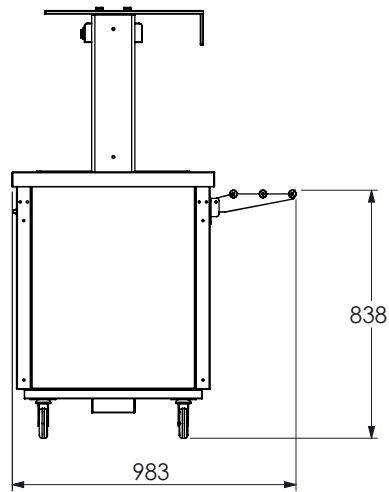
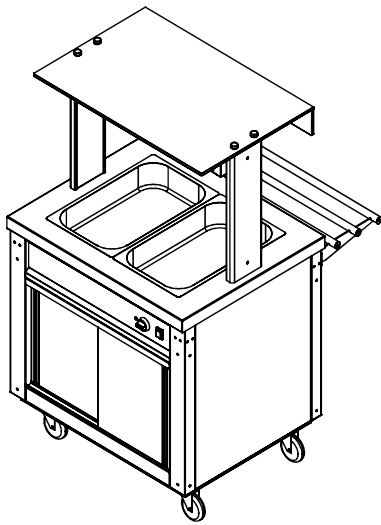

757 With tray slide in the down position

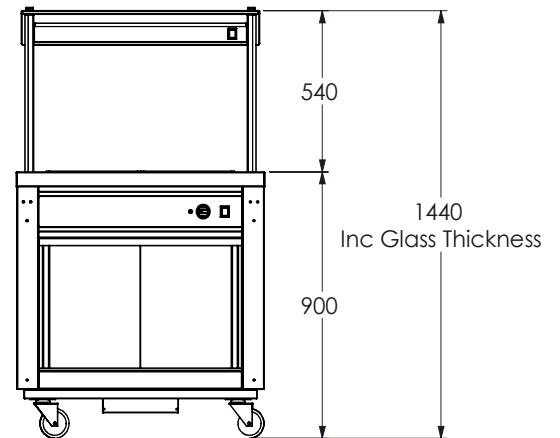
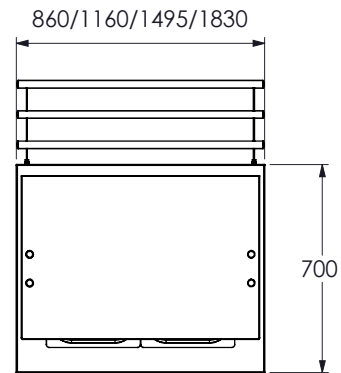

## AVAILABLE ACCESSORIES

- Island glass or Assisted glass at an additional cost